

REV.	DESCRIPTION	DRAWN	CHECKED	APPROVED
A	NEW RELEASE	LJC 01/17/09'	~	

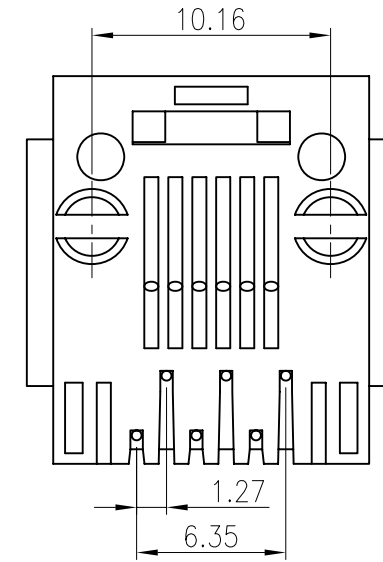
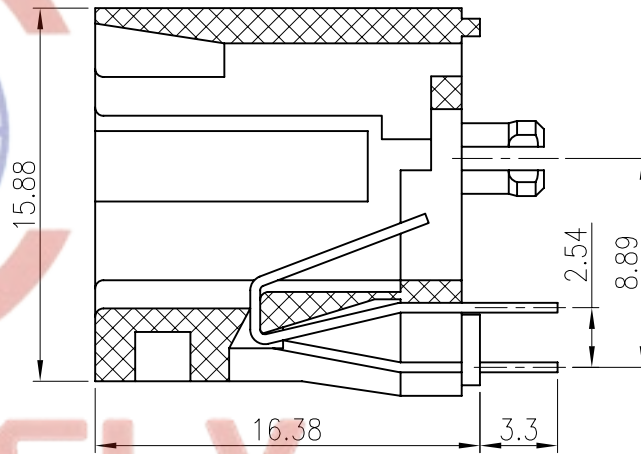
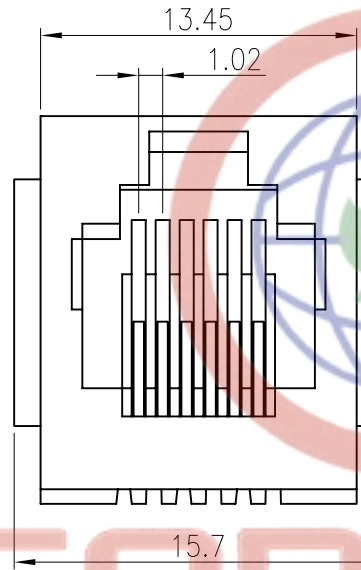

CONNFLY

SPECIFICATION

1. Insulation Resistance:1000MΩ Min.
2. Withstand Voltage:500V AC/Minute.
3. Durability:600 Mating Cycles Min.
4. Contact Resistance: 50mΩ Max.
5. Product Number Code:

DS1133-02-X X X X X

- X Ear support
- S:W/ ear
- X:W/O ear
- Housing Color
- B:Black
- A:Gray
- Contact Plating
- 0:Gold Flash
- 3:Selective 3u" Gold
- (6;15;30)Micro Inch
- No.Of Contacts
- 6:6P6C 4:6P4C
- Connector Type
- S:Socket

Tel:86-574-6350877
 Fax:86-574-6351077
 E-mail:sale@zhenyuan.com.cn
 Http://www.connfly.com.cn

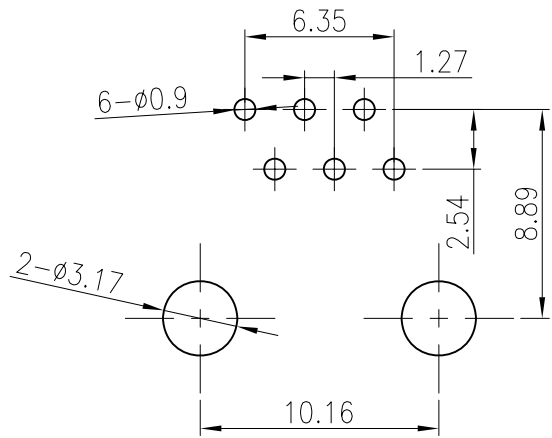

RECOMMEND PCB LAYOUT
 TOLERANCE=±0.05mm

GENERAL TOLERANCE		ANGLE TOLERANCE		PROJECTION		TITLE	PCB JACK 6p
X.	±0.60	X.	±5°	UNITS	mm	Vertical Through Type	
.X	±0.38	.X	±3°	SHEET SIZE	A4	SERIES	DS1133-02 SERIES
.XX	±0.25	.XX	±2°	晨翔电子有限公司 CONNFLY ELECTRONIC CO. LTD			
DRAWING TYPE		CUSTOMER					
SCALE		1:1 SHEET 1 OF 1					
DRAWING NO.		C-DS1133-02-XXXXX					